



SUD OUEST SYSTEME
machines outils

Drilling machine

5 AXIS

Features :

- **Ranges and axis feedrate :**

- X : 8000 mm, 20 m/min
- Y : 1700 mm, 20 m/min
- Z : 1050 mm, 20 m/min
- A : +/- 115°, 300 deg/s
- C : +/- 180°, 300 deg/s

- **Acceleration : 1 m/s²**

- **Electro spindle**

- **Power : 20 kW**
- **Axial spindle torque : 2000 or 5 000 N**
- **Speed : 18 000 tr/min**
- **Taper : HSK-A63**

- **NC : Fanuc 31i, Siemens 840DSL**

- **Options : Lubrication and micro spray by tool center, Tool changer, vibratory / orbital drilling**

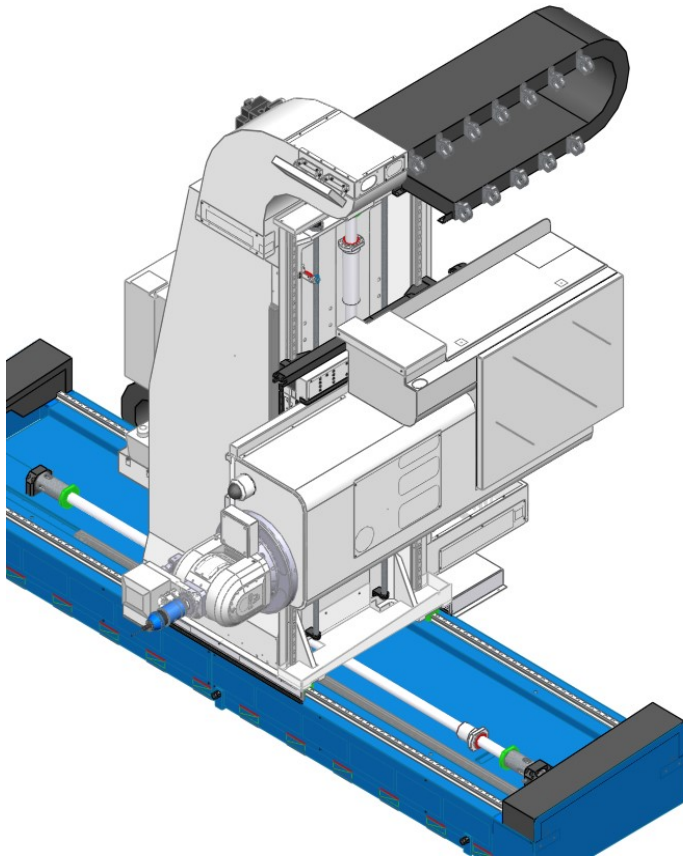

Customers working with us :

AIRBUS , LATECOERE SERVICES, SPIE





Multi-spindles milling machine

3 AXIS

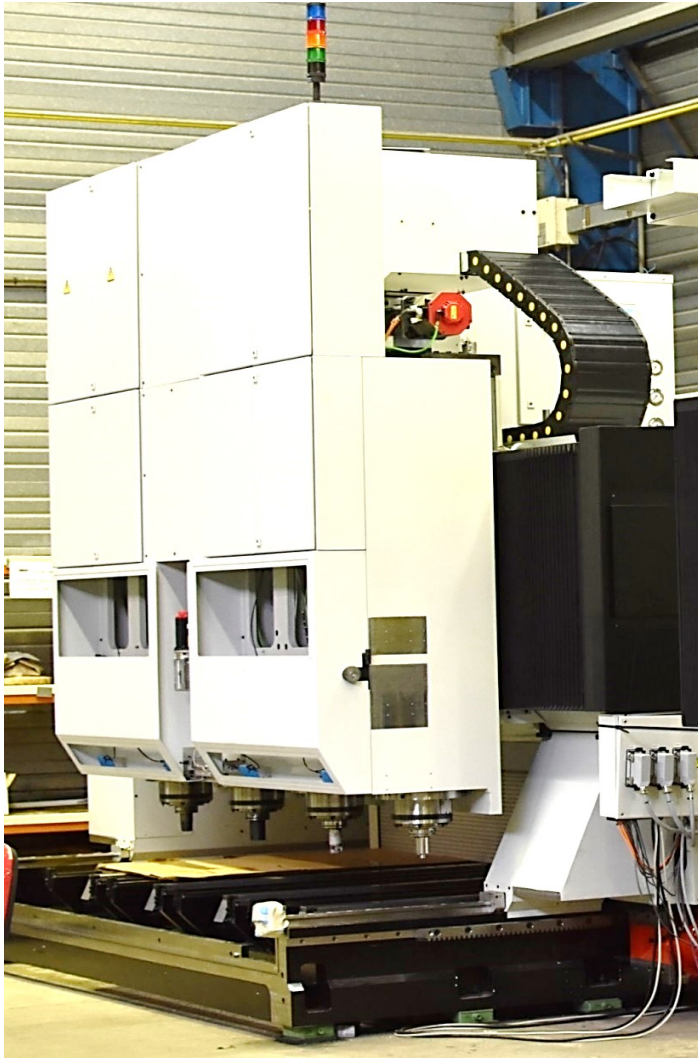

Features :

- **Ranges and axis feedrate :**
 - X : 14000 mm, 20 m/min
 - Y : 2200 mm, 15 m/min
 - Z : 700 mm, 10 m/min
- **Acceleration : 1 m/s²**
- **Electro spindles (1 up to 4)**
 - Power : 63 kW
 - Torque : 600 N/m
 - Speed : 6 000 tr/min
 - Taper : HSK-A100
- **NC : Fanuc 31i, Siemens 840DSL**
- **Automatic Tool Changer : 25 tools/spindle**
- **Options : Tool setting probes, vibration monitoring**

